



ETA-Danmark A/S
Göteborg Plads 1
DK-21590 Nordhavn
Tel. +45 72 24 59 00
Fax +45 72 24 59 04
Internet www.etadanmark.dk

Authorised and notified according
to Article 29 of the Regulation (EU)
No 305/2011 of the European
Parliament and of the Council of 9
March 2011

MEMBER OF EOTA



European Technical Assessment ETA-19/0818 of 2019/12/13

I General Part

Technical Assessment Body issuing the ETA and designated according to Article 29 of the Regulation (EU) No 305/2011: ETA-Danmark A/S

Trade name of the construction product:

EXTREME GRIP EPOXY Bonded anchor for rebar connections

Product family to which the above construction product belongs:

Post-installed rebar connections of the sizes 8 to 32 mm with EXTREME GRIP EPOXY injection mortar

Manufacturer:

Torggler Chimica S.p.A
Via Prati Nuovi, 9
IT-39020 Marlegno (BZ)
Tel. +39 0473 282400
Internet www.torggler.com

Manufacturing plant:

Torggler Chimica S.p.A
Manufacturing plant II

This European Technical Assessment contains:

25 pages including 20 annexes which form an integral part of the document

This European Technical Assessment is issued in accordance with Regulation (EU) No 305/2011, on the basis of:

European Assessment Document (EAD) no EAD 330087-00-0601 Systems for post-installed rebar connections with mortar

This version replaces:

Translations of this European Technical Assessment in other languages shall fully correspond to the original issued document and should be identified as such.

Communication of this European Technical Assessment, including transmission by electronic means, shall be in full (except the confidential Annexes referred to above). However, partial reproduction may be made, with the written consent of the issuing Technical Assessment Body. Any partial reproduction has to be identified as such.

II SPECIFIC PART OF THE EUROPEAN TECHNICAL ASSESSMENT

1 Technical description of product and intended use

Technical description of the product

The subject of this assessment are the post-installed connections, by anchoring or overlap connection joint consisting of steel reinforcing bars (rebars) in existing structures made of normal weight concrete, using injection mortar EXTREME GRIP EPOXY Bonded anchor in accordance with the regulations for reinforced concrete construction. The design of the post-installed rebar connections shall be done in accordance with EN 1992-1-1 (Eurocode 2).

Reinforcing bars with diameters from 8 to 32 mm and EXTREME GRIP EPOXY injection mortar according to Annex A3 are used for the post-installed rebar connections covered by this ETA. The steel element is placed into a drilled hole previously injected with a mortar and is anchored by the bond between embedded element, injection mortar and concrete.

The characteristic material values, dimensions and tolerances of the anchors not indicated in Annexes shall correspond to the respective values laid down in the technical documentation¹ of this European Technical Assessment.

Each mortar cartridge is marked with the identifying mark of the producer and with the trade name. The rebars are either delivered with the mortar cartridges or commercial standard rebars purchased separately.

The EXTREME GRIP EPOXY injection mortar is delivered in mortar cartridges in a difference sizes in accordance with Annex A4.

For the installed anchor see Figure given in Annex A2. The intended use specifications of the product are detailed in the Annex B1.

2 Specification of the intended use in accordance with the applicable EAD

The post-installed rebar connections may be used in normal weight concrete of a minimum grade C12/15 and maximum grade C50/60 according to EN 206-1. They

¹ The technical documentation of this European Technical Assessment is deposited at ETA-Danmark and, as far as relevant for the tasks of the Notified bodies involved in the attestation of conformity procedure, is handed over to the notified bodies.

may be used in non-carbonated concrete with the allowable chloride content of 0,40 % (C10,40) related to the cement content according to EN 206-1

The rebar connections may be used for predominantly static loads.

Fatigue, dynamic or seismic loading of post-installed rebar connections are not covered by this ETA.

The fire resistance of the post-installed rebar connections is not covered by this ETA.

The rebar connections may only be carried out in the manner, which is also possible with reinforcing bars, e.g. those in the following applications:

- an overlapping joint with existing reinforcement in a building component (Figures 1 and 2, Annex A1),
- anchoring of the reinforcement at a slab or beam support (Figure 3, Annex A1; end support of a slab, designed as simply supported, as well as appropriate reinforcement for restraint forces),
- anchoring of reinforcement of building components stressed primarily in compression (Figure 4, Annex A1),
- anchoring of reinforcement to cover the line of acting tensile force (Figure 5, Annex A1).

The post-installed rebar connections may be used in dry or wet concrete and it must not be installed in flooded holes. The post-installed rebar connections may be used overhead.

The post-installed rebar connections may be used in the temperature range -40°C to +80°C (max. short term temperature +80°C and max. long term temperature +50°C).

This ETA covers anchoring in bore holes made with hammer drilling and diamond drilling technique (wet and dry cutting system).

The performances given in Section 3 are only valid if the anchor is used in compliance with the specifications and conditions given in Annex B1 to B12

The provisions made in this European Technical Assessment are based on an assumed intended working life of the anchor of 50 years.

The indications given on the working life cannot be interpreted as a guarantee given by the producer or Assessment Body, but are to be regarded only as a means for choosing the right products in relation to the expected economically reasonable working life of the works.

3 Performance of the product and references to the methods used for its assessment

3.1 Characteristics of product

Mechanical resistance and stability (BWR1):

The essential characteristics are detailed in the Annex from C1 to C3.

Safety in case of fire (BWR2):

The essential characteristics are detailed in the Annex C1.

Safety in use (BWR4):

For basic requirement Safety in use the same criteria are valid for Basic Requirement Mechanical resistance and stability (BWR1).

Sustainable use of natural resources (BWR7)

No performance determined

Other Basic Requirements are not relevant.

3.2 Methods of assessment

The assessment of fitness of the anchor for the intended use in relation to the requirements for mechanical resistance and stability and safety in use in the sense of the Basic Requirements 1 and 4 has been made in accordance with the European Assessment Document (EAD) no EAD 330087-00-0601 Systems for post-installed rebar connections with mortar

4 Assessment and verification of constancy of performance (AVCP)

4.1 AVCP system

According to the decision 96/582/EC of the European Commission, the system(s) of assessment and verification of constancy of performance (see Annex V to Regulation (EU) No 305/2011) is 1.

5 Technical details necessary for the implementation of the AVCP system, as foreseen in the applicable EAD

Technical details necessary for the implementation of the AVCP system are laid down in the control plan deposited at ETA-Danmark prior to CE marking.

Issued in Copenhagen on 2019-12-13 by



Thomas Bruun
Managing Director, ETA-Danmark

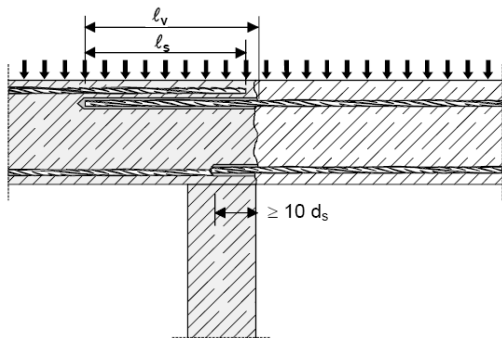

Figure 1: Overlap joint for rebar connections of slabs and beams

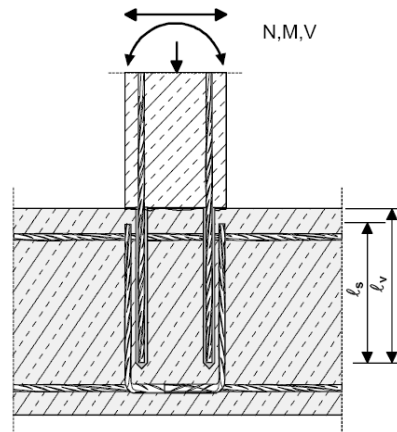

Figure 2: Overlap joint at a foundation of a column or wall where the rebars are stressed in tension

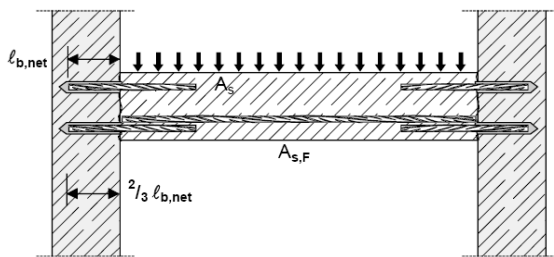

Figure 3: End anchoring of slabs or beams, designed as simply supported

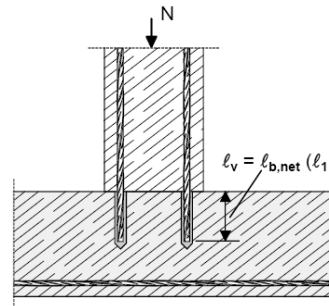

Figure 4: Rebar connection for components stressed primarily in compression. The rebars are stressed in compression

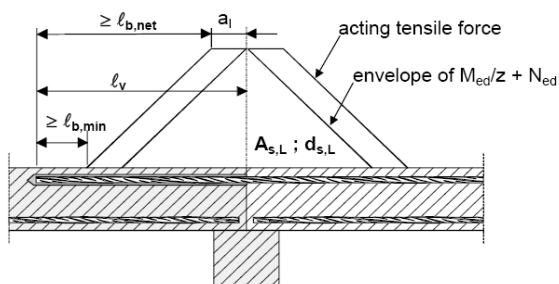

Figure 5: Anchoring of reinforcement to cover the line of acting tensile force

Note to Figure 1 to 5:

In the Figures no transverse reinforcement is plotted, the transverse reinforcement as required by EC 2 shall be present.

The shear transfer between old and new concrete shall be designed according to EC 2.

EXTREME GRIP EPOXY for post-installed rebar connection

Use of the product

Annex A1
of European
Technical Assessment
ETA-19/0818

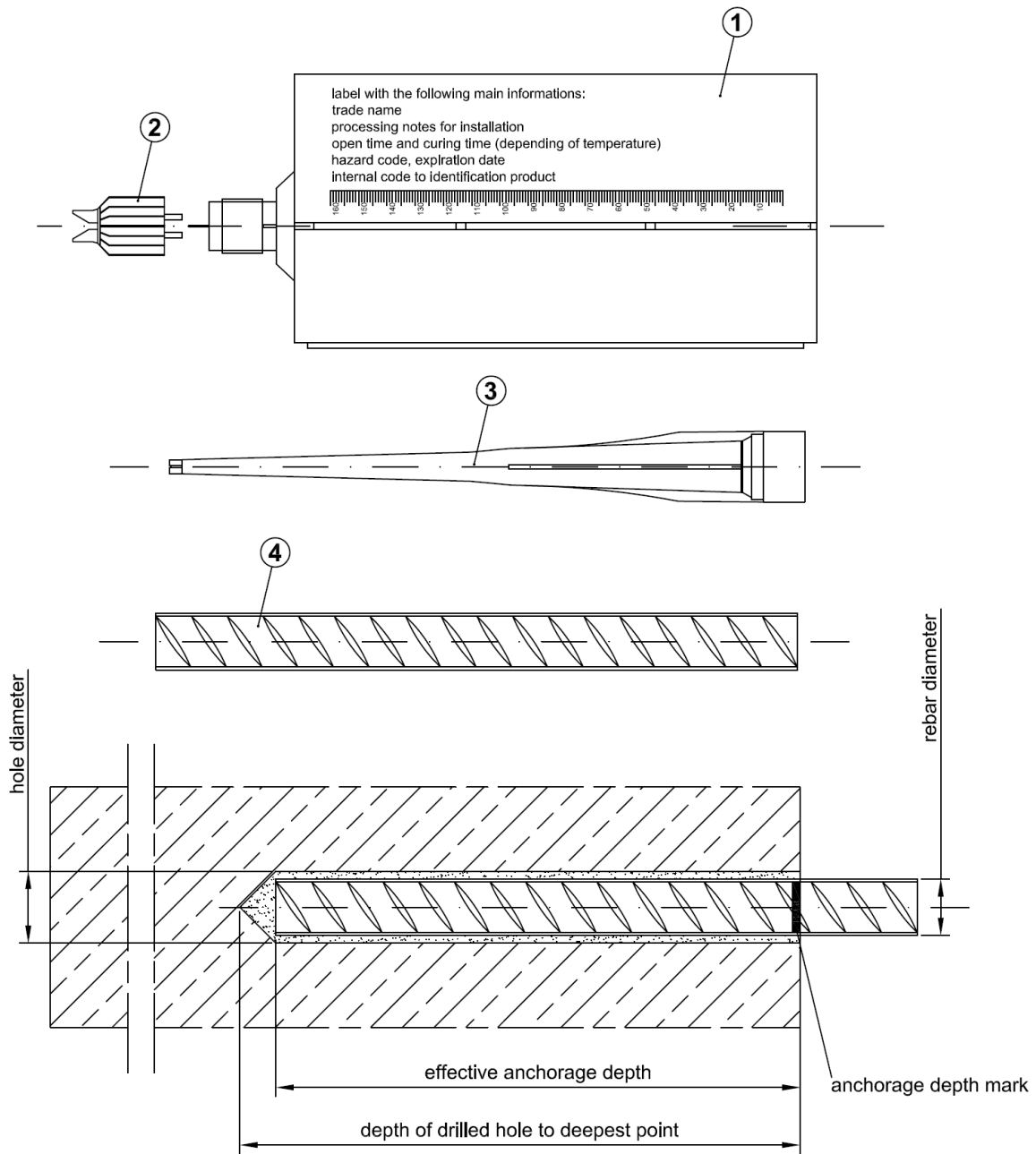

- ① Cartridge
- ② Sealing cap
- ③ Mixer
- ④ Rebar - Reinforced bar

EXTREME GRIP EPOXY for post-installed rebar connection

Product description

Annex A2
 of European
 Technical Assessment
 ETA-19/0818

Table A1: Rebar according to EN 1992-1-1, Annex C, Tables C.1 and C.2

Product form		Bars and de-coiled rods	
Class		B	C
Characteristic yield strength f_{yk} or $f_{0,2k}$ [N/mm ²]		400 to 600	
Minimum value of $k = (f_t / f_y)_k$		$\geq 1,08$	$\geq 1,15$ < 1,35
Characteristic strain at minimum force, ϵ_{uk} [%]		$\geq 5,0$	$\geq 7,5$
Bendability		Bend / Rebind test	
Maximum deviation from nominal mass (individual bar), [%]	Nominal bar size [mm]	± 6.0 ± 4.5	
	≤ 8 > 8		
Bond: Minimum relative rib area, $f_{R,min}$	Nominal bar size [mm]	0,040 0,056	
	8 to 12		
	> 12		

Rib height h: The rib height h should be: $0,05 \cdot \emptyset \leq h \leq 0,07 \cdot \emptyset$

\emptyset = nominal bar diameter

Table A2: Injection mortar

Product	Composition
EXTREME GRIP EPOXY two components injection mortar	Additive: quartz Bonding agent: epoxy resin

EXTREME GRIP EPOXY for post-installed rebar connection

Materials

Annex A3
of European
Technical Assessment
ETA-19/0818

Cartridge from 400 to 900 ml - syde by syde cartridge

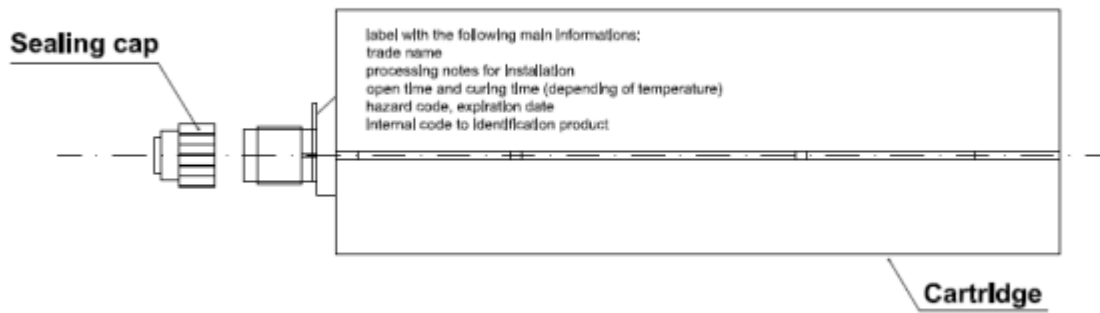

Cartridge 265 ml - peeler cartridge

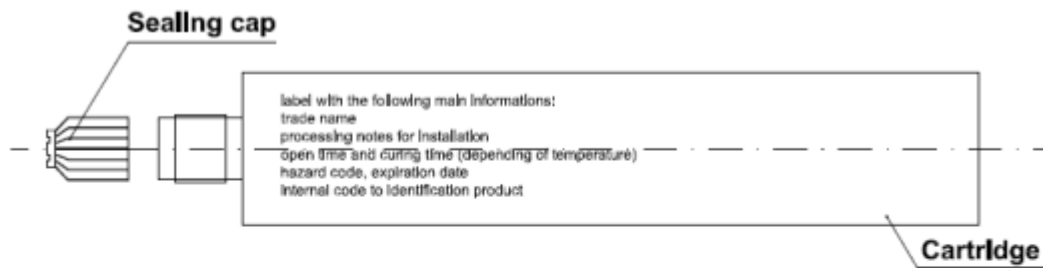

MIXER - the mixer is suitable for each type of cartridge

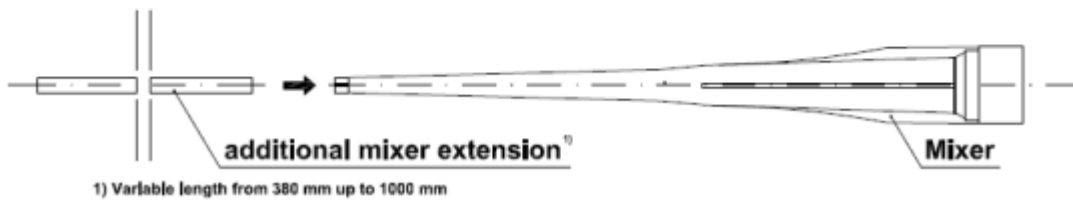

EXTREME GRIP EPOXY for post-installed rebar connection

Cartridge types and sizes

Annex A4
of European
Technical Assessment
ETA-19/0818

Specification of intended use

Anchorage subject to:

- Static and quasi-static loads.

Base materials:

- Reinforced or unreinforced normal weight concrete of strength class C12/15 at minimum to C50/60 at maximum according to EN 206-1.
- Maximum chloride content of 0,40% (CL 0,40) related to the cement content according to EN 206-1.
- Non-carbonated concrete.

Note: In case of a carbonated surface of the existing concrete structure the carbonate layer shall be removed in the area of the post-installed rebar connection with a diameter of $d_s + 60$ mm prior to the installation of the new rebar. The depth of concrete to be removed shall correspond to at least the minimum concrete cover according to EN 1992-1-1. The above may be neglected if building components are new and not carbonated and if building components are in dry conditions.

Temperature range:

- - The anchors may be used in the following temperature range:
-40°C to +80°C (max. short term temperature +80°C and max. long term temperature +50°C).

Use conditions (Environmental conditions):

- Structures subject to dry internal conditions.
- Structures subject to external atmospheric exposure including industrial and marine environment).
- Structures subject to permanently damp internal conditions if no particular aggressive conditions exist.

Note: Particular aggressive conditions are e.g. permanent, alternating immersion in seawater or the splash zone of seawater, chloride atmosphere of indoor swimming pools or atmosphere with extreme chemical pollution (e.g. in desulphurization plants or road tunnels where de-icing materials are used).

Design:

- Anchorages are designed under the responsibility of an engineer experienced in anchorages and concrete work.
- Verifiable calculation notes and drawings are prepared taking into account of the forces to be transmitted.
- Design according to EN 1992-1-1 and Annex B2.
- The actual position of the reinforcement in the existing structure shall be determined on the basis of the construction documentation and taken into account when designing.

Installation:

- Dry or wet concrete (use category I1).
- It must not be installed in flooded holes.
- Installation direction D3 (downward and horizontal and upwards installation).
- Hole drilling by hammer drill and diamond drilling machine (dry and wet cutting system).
- Installation of the post-installed rebars shall be done only by suitable trained installer and under supervision on the site.
- Check the position of the existing rebars (if the position of existing rebars in not known it shall be determined using a rebar detector suitable for this purpose as well as on the basis of the construction documentation and then marked on the building component for the overlap joint).

EXTREME GRIP EPOXY for post-installed rebar connection	Annex B1
Intended use - Specification	of European Technical Assessment ETA-19/0818

General design rules of construction for post-installed rebars

Only tension forces in the axis of the rebar may be transmitted.

The transfer of shear forces between new concrete and existing structure shall be designed additionally according to EN 1992-1-1.

The joints for concreting must be roughened to at least such an extent that aggregate protrude.

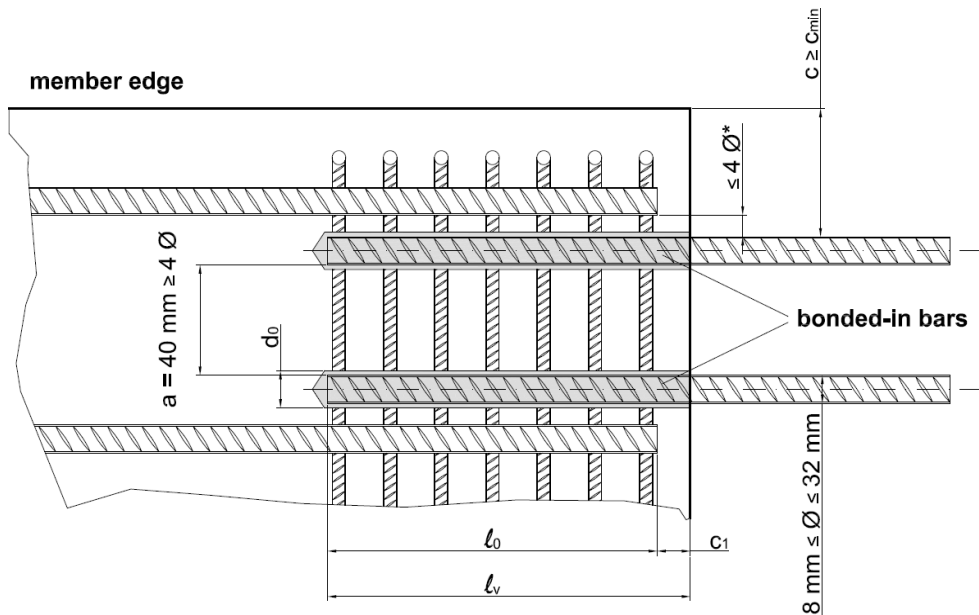

* If the clear distance between overlapping rebars is greater than $4 \cdot \emptyset$ the overlap length shall be enlarged by the difference between the clear distance and $4 \cdot \emptyset$.

l_0 – lap length acc. to EN 1992-1-1, clause 8.7.3

l_v – effective embedment depth; $l_v \geq l_0 + c_1$

c – concrete cover of post-installed rebar

c_{min} – minimum concrete cover acc. to Annex B3 and EN 1992-1-1, clause 4.4.1.2.

c_1 – concrete cover at end-face of existing rebar

d_0 – nominal drill bit diameter acc. to Annex B3

\emptyset – rebar diameter (ds)

EXTREME GRIP EPOXY for post-installed rebar connection

Intended use. General construction rules for post-installed rebars

Annex B2
of European
Technical Assessment
ETA-19/0818

Table B1: Drill bit diameter and setting depth¹⁾

Rebar diameter [mm]		Ø8	Ø10	Ø12	Ø14	Ø16	Ø20	Ø25	Ø28	Ø32
HD ²⁾ DD ³⁾	Nominal drill hole d ₀ [mm]	12	14	16	18	20	25	30	35	40
HD ²⁾ DD ³⁾	Min anchorage depth l _{b,min} [mm]	115	145	170	200	230	285	355	400	455
HD ²⁾ DD ³⁾	Min overlap joint depth l _{0,min} [mm]	200	200	200	210	240	300	375	420	480
HD ²⁾ DD ³⁾	Max anchorage depth l _{v,max} [mm]	700	900	1100	1300	1400	1800	2200	2500	2500

- 1) According to EN 1992-1-1: l_{b,min} (8.6) and l_{0,min} (8.11) with maximum yield stress for rebar BSt 500S, $\gamma_M = 1,15$, $\alpha_6 = 1,0$, concrete C20/25 with $f_{bd} = 2,30 \text{ N/mm}^2$ and good bond condition.
- 2) HD: hammer drilling method.
- 3) DD: diamond drilling method (dry and wet cutting system).

Minimum concrete cover (see Annex B2):

$$c_{\min} = 30 \text{ mm} + 0,06 \cdot l_v \geq 2 \cdot \varnothing \text{ for } \varnothing < 25 \text{ mm}$$

$$c_{\min} = 40 \text{ mm} + 0,06 \cdot l_v \geq 2 \cdot \varnothing \text{ for } \varnothing \geq 25 \text{ mm}$$

The minimum concrete cover according to EN 1992-1-1 shall be observed.

Minimum clear spacing between two post-installed rebars:

$$a = 40 \text{ mm} \geq 4 \cdot \varnothing$$

EXTREME GRIP EPOXY for post-installed rebar connection

Installation data

Annex B3
of European
Technical Assessment
ETA-11/0344

Table B2: Minimum curing time¹⁾

Concrete temperature	Processing time	Minimum curing time ³⁾
0°C ²⁾	3 h 20 min	54 h
5°C ²⁾	2 h 30 min	41 h
10°C	1 h 40 min	28 h
15°C	1 h 10 min	22 h
20°C	50 min	16 h
25°C	30 min	14 h
30°C	20 min	12 h

- 1) The minimum time from the end of the mixing to the time when the anchor may be torque or loaded (whichever is longer).
- 2) Minimum resin temperature recommended, for injection between 5°C and 0°C, equal to 10°C.
- 3) Minimum curing time for dry and wet conditions.
- 4) Maximum resin temperature for maximum anchorage length equal to 24 °C.

EXTREME GRIP EPOXY for post-installed rebar connection

Curing time

Annex B4
of European
Technical Assessment
ETA-19/0818

Manual blower pump: nominal dimensions

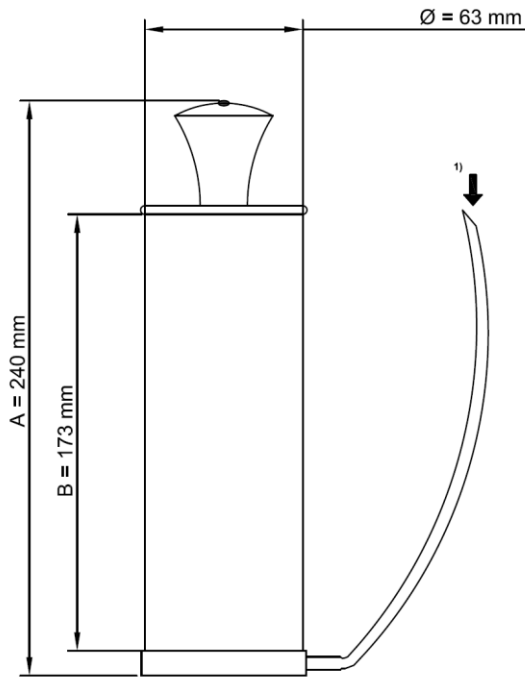

It is possible to use the mixer extensor with the manual blower pump.

However it is possible to blow the hole using the mechanical air system (compressed air) also with the mixer extension



Suitable min pressure 6 bar at 6 m³/h
Oil-free compressed air
Recommended air gun with an orifice opening of minimum 3.5 mm in diameter

1) Position to Insert the mixer extension



Mixer extension (from 380 mm to 1000 mm) with nominal diameter equal to 8 mm
For the hole with depth grater 1000 mm up to 2500 mm it is possible use the special mixer extension (see Annex B7) for blower operation.

EXTREME GRIP EPOXY for post-installed rebar connection

Cleaning tools (1)

Annex B5
of European
Technical Assessment
ETA-19/0818

Standard brush

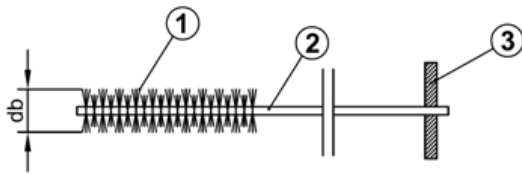

- ① Steel bristles
- ② Steel stem
- ③ Wood handle

Table 7: Standard brush diameter

Rebar diameter - Ø			Ø8	Ø10	Ø12	Ø14	Ø16
d₀	Nominal drill hole	[mm]	12	14	18	18	20
d_b	Brush diameter	[mm]	14	16	20	20	22

Special brush

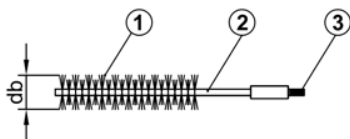

- ① Steel bristles
- ② Steel stem
- ③ Threaded connection for drilling tool extension
- ④ Extension special brush
- ⑤ Drilling tool connection (SDS connection)



Table 8: Special brush diameter (mechanical brush)

Rebar diameter - Ø			Ø8	Ø10	Ø12	Ø14	Ø16	Ø20	Ø25	Ø28	Ø32
d₀	Nominal drill hole	[mm]	12	14	16	18	20	25	30	35	40
d_b	Brush diameter	[mm]	14	16	18	20	22	27	32	37	42

EXTREME GRIP EPOXY for post-installed rebar connection

Cleaning tools (2)

Annex B6
of European
Technical Assessment
ETA-19/0818

Use the mixer extension (assembled on the standard mixer) for the injection up to 300 mm if necessary.

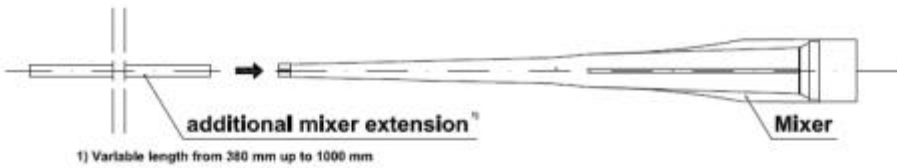

Use this system for special conditions:

Tools for installation in special condition

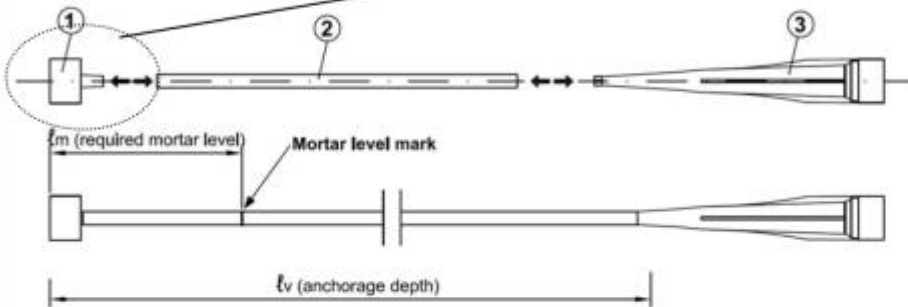

Insert the special mixer extension in the inner diameter of the injection plug up to reach the top of the plug

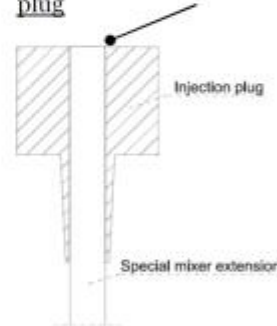

- ① Injection plug (nominal diameter according to the nominal diameter of drilled hole)
- ② Special mixer extension (variable length with nominal diameter 10 mm)
Mark the required mortar level ℓ_m and embedment depth ℓ_v with tape or marker on the injection extension. Quick estimation: $\ell_m = 1/3 \cdot \ell_v$
Continue injection until the mortar level mark ℓ_m becomes visible.
- ③ Standard mixer (suitable for all size of cartridge)

These tools allow the application in special conditions:
- installation with anchorage depth greater than 300 mm
- overhead installation.

For these applications is recommended the use of the injection pneumatic pump.

System assembled

- ① Injection plug
- ② Special mixer extension
- ③ Standard mixer
- ④ Cartridge
- ⑤ Sample of Injection pneumatic pump

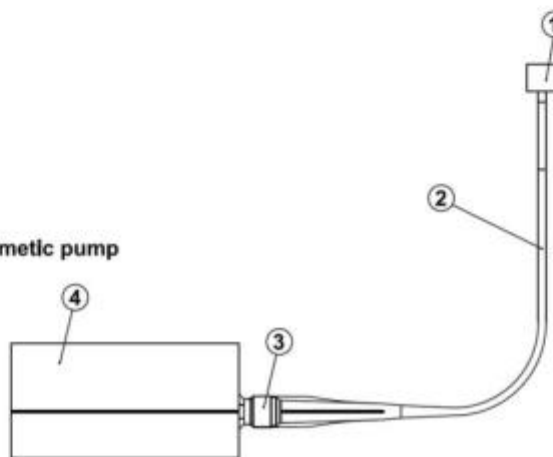

EXTREME GRIP EPOXY for post-installed rebar connection

Tools for injection (1)



Annex B7
of European
Technical Assessment
ETA-19/0818



Resin injection pump details		
Pump example	Size cartridge	Type
	900 ml	Pneumatic
	from 450 ml to 480 ml	Pneumatic
	400 ml	Pneumatic
	from 450 ml to 480 ml	Manual (up to 300 mm anchorage depth)
	400 ml	Manual (up to 300 mm anchorage depth)
	265 ml	Manual (up to 300 mm anchorage depth)

EXTREME GRIP EPOXY for post-installed rebar connection

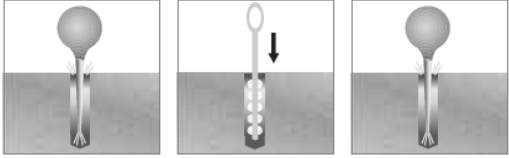
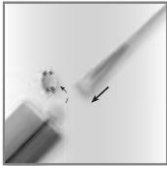
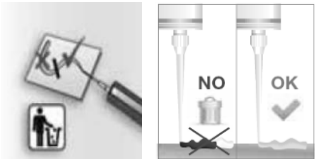
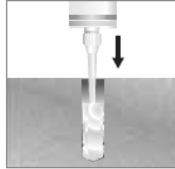
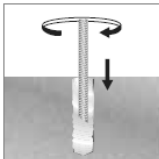
Tools for injection (2)

Annex B8
of European
Technical Assessment
ETA-19/0818

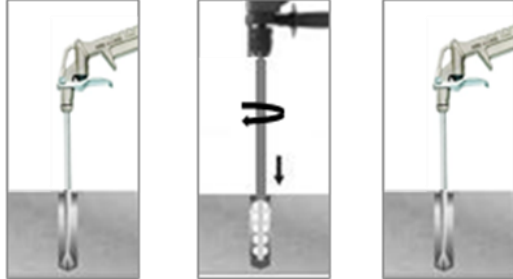
1		<p>Drill the hole with the correct diameter and depth using a rotary percussive machine. Check the perpendicularity of the hole during the drilling operation.</p>
2	 <p>4x 4x 4x</p> <p>Blower Manual Pump Standard Brush Blower Manual Pump if necessary use a mixer extension for the blower operation (see Annex B7)</p>	<p>Clean the hole from drilling dust: the hole shall be cleaned by at least 4 blowing operations, by at least 4 brushing operations followed again by at least 4 blowing operations; before brushing clean the brush and check (see Annex B6, standard brush) if the brush diameter is sufficient. For the blower tools see Annex B5.</p>
3		<p>Unscrew the front cup, screw on the mixer and insert the cartridge in the gun.</p>
4		<p>Before starting to use the cartridge, eject a first part of the product, being sure that the two components are completely mixed. The complete mixing is reached only after that the product, obtained by mixing the two components, comes out from the mixer with an uniform color.</p>
5	 <p>if necessary use a mixer extension for the injection (see Annex B7)</p>	<p>Fill the drilled hole uniformly starting from the drilled hole bottom, in order to avoid entrapment of the air; remove the mixer slowly bit by bit during pressing-out; filling the drill hole with a quantity of the injection mortar corresponding to 2/3 of the drill hole depth.</p>
6	   <p>ATTENTION: Use the rods dry and free oil and other contaminants</p>	<p>Insert immediately the rod, marked according to the proper anchorage depth, slowly and with a slight twisting motion, removing excess of injection mortar around the rod. Observe the processing time according Annex B4. Wait the curing time according Annex B4.</p>
<p>EXTREME GRIP EPOXY for post-installed rebar connection</p>		<p>Annex B9 of European Technical Assessment ETA-19/0818</p>
<p>Procedure up to 300 mm depth (hammer drilling)</p>		

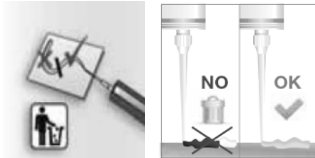
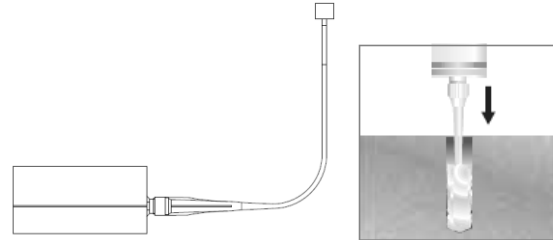
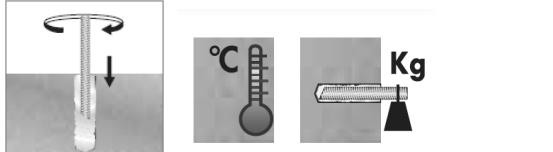
1		<p>Drill the hole with the correct diameter and depth using a rotary percussive machine. Check the perpendicularity of the hole during the drilling operation.</p>
2	 <p>4 x 5 seconds 4x 4 x 5 seconds ATTENTION: compressed air free oil</p>	<p>Clean the hole from drilling dust: the hole shall be cleaned by at least 4 blowing operations (5 seconds for single operation) with compressed air, by at least 4 brushing operations with special brush followed again by at least 4 blowing operations (5 seconds for single operation) with compressed air. Before brushing clean the brush and check (see Annex B6, special brush) if the brush diameter is sufficient. For the blower tools see the Annex B5.</p>
3		<p>Unscrew the front cup of the cartridges, screw on the mixer and insert the cartridge in the proper pneumatic-pump.</p>
4		<p>Before starting to use the cartridge, eject a first part of the product, being sure that the two components are completely mixed. The complete mixing is reached only after that the product, obtained by mixing the two components, comes out from the mixer with an uniform color.</p>
5		<p>Before starting the injection, assemble the system according to Annex B7. After that, fill the drilled hole uniformly from the drilled hole bottom, in order to avoid entrapment of the air; remove the special mixer extension with injection plug slowly bit by bit during pressing-out; filling the drill hole with a quantity of the injection mortar corresponding to 2/3 of the drill hole depth. Procedure for overhead application is detailed in Annex B12.</p>
6	 <p>ATTENTION: Use the rods dry and free oil and other contaminants</p>	<p>Insert immediately the rod, marked according to the proper anchorage depth, slowly and with a slight twisting motion, removing excess of injection mortar around the rod. Observe the processing time according Annex B4. Wait the curing time according Annex B4.</p>
<p>EXTREME GRIP EPOXY for post-installed rebar connection</p>		<p>Annex B10 of European Technical Assessment ETA-19/0818</p>
<p>Procedure up to max anchorage depth (hammer drilling)</p>		

1		<p>Drill the hole with the correct diameter and depth using a core drill machine. Check the perpendicularity of the hole during the drilling operation. Remove completely the core from the hole.</p>
----------	---	---

After operation 1, if the diamond drilling machine used has a dry cutting system to proceed with the installation procedure according to the point 2. Instead if it is used a wet cutting system before of the point 2 the following operation must be done:

- flush hole 2 times by inserting a water hose to the back of the hole until water runs clear;
- brush 2 times with the proper special brush. Before brushing clean the brush and check (see Annex B6, special brush) if the brush diameter is sufficient;
- flush again 2 times until water runs clear;
- remove all standing water completely (using for example vacuum system or compressed air free oil).

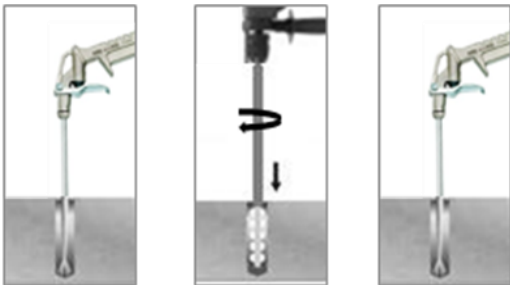
2	 <p style="text-align: center;"> 4 x 5 seconds 6x 4 x 5 seconds ATTENTION: compressed air free oil </p>	<p>Clean the hole from drilling dust: the hole shall be cleaned by at least 4 blowing operations (5 seconds for single operation) with compressed air, by at least 4 brushing operations with special brush followed again by at least 4 blowing operations (5 seconds for single operation) with compressed air. Before brushing clean the brush and check (see Annex B6, special brush) if the brush diameter is sufficient. For the blower tools see the Annex B5.</p>
----------	--	--

After the operation above, to follow the operations from 3 to 6 on the previous Annex B9 and B10 in function of the depth of the hole.

EXTREME GRIP EPOXY for post-installed rebar connection	Annex B11
Procedure with diamond drilling (wet and dry) for all depths	of European Technical Assessment ETA-19/0818

Overhead installation procedure

In addition to standard procedure, for overhead installation, following the below procedure

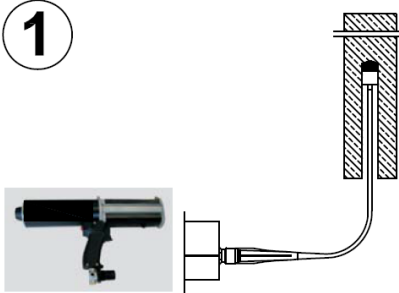
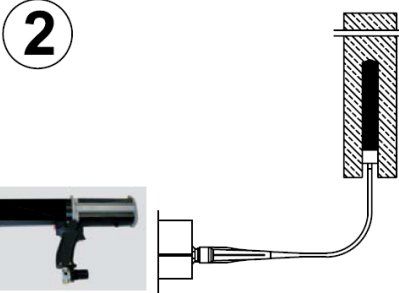
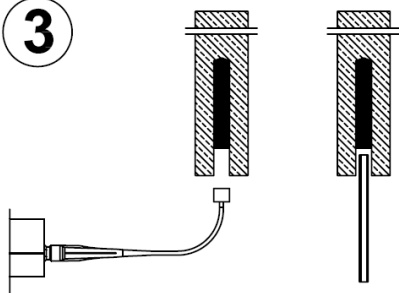
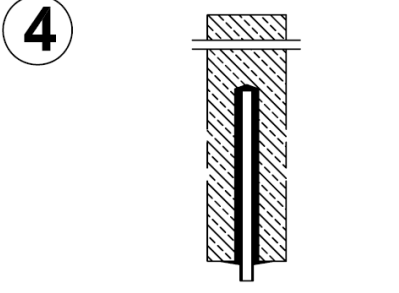
<p>1</p> 	<p>1 - Start injection</p> <p>Inject from the bottom of the hole. Maintain this position during the injection phase.</p>
<p>2</p> 	<p>2 - Injection phase</p> <p>Inject the product about 2/3 of the hole depth. During the injection maintain this position to assure the correct installation</p>
<p>3</p> 	<p>3 - End injection</p> <p>Remove the injection plug. Insert immediately the rod (turn the rod during the insertion).</p>
<p>4</p> 	<p>4 - End installation</p> <p>To avoid the slipping of the rod during the open time of the product (due to the rod own weighth) use a temporary interlocking element (for ex. wedge of wood)</p>

EXTREME GRIP EPOXY for post-installed rebar connection

Overhead application

Annex B12

of European
Technical Assessment
ETA-19/0818

Table C1: Design values of the ultimate bond resistance f_{bd} according to EN 1992-1-1

ESSENTIAL CHARACTERISTICS	PERFORMANCE								
* Design bond strength f_{bd} according to EN 1992-1-1 [N/mm²] for perforation with hammer drilling machine	C12/15	C16/20	20/25	C25/30	C30/37	C35/45	C40/50	C45/55	C50/60
da Ø8 a Ø28	1,60	2,00	2,30	2,70	3,00	3,40	3,70	4,00	4,30
Ø32	1,60	2,00	2,30	2,70	3,00	3,40	3,70	4,00	4,00
* Design bond strength f_{bd} according to EN 1992-1-1 [N/mm²] for perforation with diamond drilling machine (dry and wet cutting system)	C12/15	C16/20	20/25	C25/30	C30/37	C35/45	C40/50	C45/55	C50/60
da Ø8 a Ø25	1,60	2,00	2,30	2,70	3,00	3,40	3,70	4,00	4,30
Ø28	1,60	2,00	2,30	2,70	3,00	3,40	3,70	3,70	3,70
Ø32	1,60	2,00	2,30	2,70	3,00	3,00	3,00	3,00	3,00

* Values valid only for good bond condition according to EN 1992-1-1.
For other bond conditions multiply the values for 0,7

Table C2: Amplification factor α_{lb} related to concrete class and drilling method:

Concrete Class	Drilling method	Bar size	Amplification factor α_{lb}
C 12/15 to C50/60	Hammer drilling and diamond core drilling	8mm to 32mm	1,0

Table C3: Bond efficiency factor k_b related to concrete class and drilling method:

ESSENTIAL CHARACTERISTICS	PERFORMANCE								
k_b for perforation with hammer drilling machine	C12/15	C16/20	20/25	C25/30	C30/37	C35/45	C40/50	C45/55	C50/60
da Ø8 a Ø28	1,00	1,00	1,00	1,00	1,00	1,00	1,00	1,00	1,00
Ø32	1,00	1,00	1,00	1,00	1,00	1,00	1,00	1,00	0,93
k_b for perforation with diamond drilling machine (dry and wet cutting system)	C12/15	C16/20	20/25	C25/30	C30/37	C35/45	C40/50	C45/55	C50/60
da Ø8 a Ø25	1,00	1,00	1,00	1,00	1,00	1,00	1,00	1,00	1,00
Ø28	1,00	1,00	1,00	1,00	1,00	1,00	1,00	0,92	0,86
Ø32	1,00	1,00	1,00	1,00	1,00	0,88	0,81	0,75	0,70

Table C4: Resistance to fire

ESSENTIAL CHARACTERISTICS	PERFORMANCE
Resistance to fire	No performance assessed

Table C5: Reaction to fire

ESSENTIAL CHARACTERISTICS	PERFORMANCE
Reaction to fire	In the final application the thickness of the mortar layer is about 1 to 2 mm and most of the mortar is material classified class A1 according to EC Decision 96/603/EC. Therefore it may be assumed that the bonding material (synthetic mortar or a mixture of synthetic mortar and cementitious mortar) in connection with the metal anchor in the end use application do not make any contribution to fire growth or to the fully developed fire and they have no influence to the smoke hazard.

EXTREME GRIP EPOXY for post-installed rebar connection

Performance for static and quasi-static loads: Resistances

Annex C1
of European
Technical Assessment
ETA-19/0818

Values for pre-calculation of anchoring Examples for anchorage length ¹⁾ for rebars ($f_{y,k} = 500 \text{ N/mm}^2$) on concrete C20/25 ($f_{bd} = 2,3 \text{ N/mm}^2$) Values for hammer drilling (HD) and diamond drilling (DD) perforation technique							
Rebar Ø	Tensile load for Bst 500	$\alpha_1 = \alpha_2 = \alpha_3 = \alpha_4 = \alpha_5 = 1,0$			$\alpha_1 = \alpha_3 = \alpha_4 = 1,0$ and α_2 or $\alpha_5 = 0,7$		
		Anchorage length l_{bd}	Tension load	Mortar volume $V^2)$	Anchorage length l_{bd}	Tension load	Mortar volume $V^2)$
[mm]	[kN]	[mm]	[kN]	[ml]	[mm]	[kN]	[ml]
8	21,85	115	6,65	8,50	115	9,50	8,50
		180	10,40	13,31	180	14,86	13,31
		250	14,45	18,48	200	16,52	14,78
		320	18,50	23,65	220	18,17	16,26
		378	21,85	27,95	265	21,85	19,56
10	34,15	145	10,48	12,86	145	14,97	12,86
		230	16,62	20,40	230	23,74	20,40
		310	22,40	27,50	260	26,84	23,06
		390	28,18	34,59	290	29,93	25,72
		473	34,15	41,92	331	34,15	29,34
12	49,17	170	14,74	17,59	170	21,06	17,59
		270	23,41	27,94	270	33,44	27,94
		370	32,08	38,29	300	37,16	31,05
		470	40,75	48,64	330	40,88	34,15
		567	49,17	58,69	397	49,17	41,08
14	66,93	200	20,23	23,65	200	28,90	23,65
		320	32,37	37,85	320	46,24	37,85
		440	44,51	52,04	360	52,02	42,58
		560	56,65	66,23	400	57,81	47,31
		662	66,93	78,25	463	66,93	54,78
16	87,42	230	26,59	30,60	230	37,99	30,60
		360	41,62	47,90	360	59,46	47,90
		490	56,65	65,20	400	66,06	53,22
		620	71,68	82,49	440	72,67	58,54
		756	87,42	100,61	529	87,42	70,43
20	136,59	285	41,19	59,25	285	58,84	59,25
		450	65,03	93,55	450	92,90	93,55
		620	89,60	128,90	500	103,22	103,95
		790	114,17	164,24	550	113,55	114,34
		945	136,59	196,50	662	136,59	137,55
25	213,42	355	64,13	90,21	355	91,61	90,21
		560	101,16	142,30	560	144,51	142,30
		770	139,09	195,66	750	193,54	190,57
		980	177,03	249,02	800	206,45	203,28
		1181	213,42	300,21	827	213,42	210,15
28	267,72	400	80,93	162,99	400	115,61	162,99
		630	127,46	256,71	700	202,32	285,24
		860	173,99	350,44	800	231,22	325,99
		1090	220,53	444,16	900	260,12	366,73
		1323	267,72	539,20	926	267,72	377,44
32	349,67	455	105,21	242,16	455	150,29	242,16
		720	166,48	383,20	760	251,04	404,49
		980	226,60	521,58	840	277,47	447,07
		1240	286,71	659,96	920	303,89	489,64
		1512	349,67	804,87	1059	349,67	563,41

1) Tabulated maximum tension loads are valid for good bond condition according to EN 1992-1-1.

For all other bond condition the values for tension load must be multiplied by 0,7

2) The mortar volume V can be estimated using the equation: $V = l_b \pi (d_0^2 - d^2) / (4 \times 0,85)$ with the nominal hole diameter

EXTREME GRIP EPOXY for post-installed rebar connection

Design Values for anchoring connection

Annex C2
of European
Technical Assessment
ETA-19/0818

<p align="center">Values for pre-calculation of lap splice lengths Examples for the lap splice length ¹⁾ for rebars ($f_{y,k} = 500 \text{ N/mm}^2$) on concrete C20/25 ($f_{bd} = 2,3 \text{ N/mm}^2$) Values for hammer drilling (HD) and diamond drilling (DD) perforation technique</p>							
Rebar \varnothing	Tensile load for Bst 500	$\alpha_1 = \alpha_2 = \alpha_3 = \alpha_5 = \alpha_6 = 1,0$			$\alpha_1 = \alpha_3 = \alpha_6 = 1,0$ and α_2 or $\alpha_5 = 0,7$		
		Lap splice length l_0	Tension load	Mortar volume $V^2)$	Lap splice length l_0	Tension load	Mortar volume $V^2)$
[mm]	[kN]	[mm]	[kN]	[ml]	[mm]	[kN]	[ml]
8	21,85	200	11,56	14,78	200	16,52	14,78
		240	13,87	17,74	240	19,82	17,74
		280	16,19	20,70	265	21,85	19,56
		320	18,50	23,65	-	-	-
		378	21,85	27,95	-	-	-
10	34,15	200	14,45	17,74	200	20,64	17,74
		270	19,51	23,95	235	24,26	20,85
		340	24,57	30,16	270	27,87	23,95
		410	29,63	36,37	305	31,48	27,05
		473	34,15	41,92	331	34,15	29,34
12	49,17	200	17,34	20,70	200	24,77	20,70
		290	25,15	30,01	250	30,97	25,87
		380	32,95	39,33	300	37,16	31,05
		470	40,75	48,64	350	43,35	36,22
		567	49,17	58,69	397	49,17	41,08
14	66,93	210	21,24	24,84	210	30,35	24,84
		320	32,37	37,85	270	39,02	31,93
		430	43,50	50,86	330	47,69	39,03
		540	54,63	63,87	390	56,36	46,13
		662	66,93	78,25	463	66,93	54,78
16	87,42	240	27,75	31,93	240	39,64	31,93
		370	42,78	49,23	310	51,20	41,25
		500	57,81	66,53	380	62,76	50,56
		630	72,83	83,83	450	74,32	59,88
		756	87,42	100,61	529	87,42	70,43
20	136,59	300	43,35	62,37	300	61,93	62,37
		460	66,48	95,63	390	80,51	81,08
		620	89,60	128,90	480	99,09	99,79
		780	112,72	162,16	570	117,68	118,50
		945	136,59	196,50	662	136,59	137,55
25	213,42	375	67,74	95,29	375	96,77	95,29
		580	104,77	147,38	670	172,90	170,25
		780	140,90	198,20	780	201,29	198,20
		980	177,03	249,02	800	206,45	203,28
		1181	213,42	300,21	827	213,42	210,14
28	267,72	420	84,97	171,14	420	121,39	171,14
		650	131,51	264,86	720	208,10	293,39
		880	178,04	358,59	810	234,11	330,06
		1110	224,57	452,31	900	260,12	366,73
		1323	267,72	539,20	926	267,72	377,44
32	349,67	480	110,99	255,47	480	158,55	255,47
		740	171,10	393,84	740	244,43	393,84
		1000	231,22	532,22	1000	330,32	532,22
		1260	291,34	670,60	1260	349,67	670,60
		1512	349,67	804,87	1059	349,67	563,41

1) Tabulated maximum tension loads are valid for good bond condition according to EN 1992-1-1.

For all other bond condition the values for tension load must be multiplied by 0,7

2) The mortar volume V can be estimated using the equation: $V = l_0 \pi (d_0^2 - d^2) / (4 \times 0,85)$ with the nominal hole diameter

EXTREME GRIP EPOXY for post-installed rebar connection

Design Values for anchoring connection

Annex C3
of European
Technical Assessment
ETA-19/0818

TERMINOLOGY AND SYMBOLS	
∅	Nominal diameter of the reinforced bar
d ₀	Drill hole diameter
lv	Setting depth
a	Minimum clear spacing between two post-installed rebar
C _{min}	Minimum concrete cover
l _{b,min}	Minimum anchorage length
l _{o,min}	Minimum overlap joint length
l _{b,reqd}	Required basic anchorage length
NPA	No Performance Assessed
EXTREME GRIP EPOXY	
Terminology and symbols	
Annex C4 of European Technical Assessment ETA-19/0818	